

## INNOVATIVE AC-DC POWER SUPPLY: A VERSATILE DUAL-MODE APPROACH TO LOCALIZED SUSTAINABLE ENERGY SOLUTION

Angelica O. Cortez<sup>1,\*</sup> 

<sup>1</sup> Nueva Ecija University of Science and Technology, Cabanatuan City, Philippines  
Corresponding author email: [cortez.angelica@neust.edu.ph](mailto:cortez.angelica@neust.edu.ph)

### Article Info

Received: Feb 02, 2024

Revised: Apr 17, 2024

Accepted: May 19, 2025

OnlineVersion: Jun 08, 2025

### Abstract

In developing countries like the Philippines, outages of electricity supply in countryside are common caused by calamities resulting to isolation, thus, affecting the quality of life and delivery of instruction in the affected area. The developed Innovative AC-DC Power Supply Dual-Mode Distribution (ICPS-DMD) is a device created through product developmental research to provide a localized sustainable energy solution for isolated community households and schools in the mountainous Sitio Cabog in Dingalan, Aurora where the university adopted school is located. Validated assessment instruments with *Cronbach Alpha* = 0.94 were developed and utilized. Licensed electrical engineers employed in the university as experts assessed its design, materials used, and safety while local classroom teachers and parents, assessed the ICPS-DMD for functionality, usability, and safety. Data were analyzed employing one-tailed t-test for independent variables, One-way ANOVA and PostHoc Analysis for Multiple Comparison using SPSS v. 20. The ICPS-DMD facilitates and controls the direct use and safe utilization of 12Vdc electricity supply from a car battery and its conversion to 220Vac to provide electricity for household gadgets, appliances and instructional devices. Test results confirmed that the design and materials used to develop ICPS-DMD passed the assessment of experts with F-test = 2.233 and PostHoc analysis revealed no significant differences on the results. Said device was rated very functional, very useful, and very safe by the respondents with t-test=-1.80 in providing localized electricity supply for both 12Vdc and 220Vac powered devices. The device received patent recognition from the Intellectual Property Office of the Philippines.

**Keywords:** 12Vdc Power Supply, 220Vac Power Supply, ICPS-DMD, Dual-Mode distribution



© 2025 by the author(s)

This article is an open access article distributed under the terms and conditions of the Creative Commons Attribution (CC BY) license (<https://creativecommons.org/licenses/by/4.0/>).

### INTRODUCTION

The electricity supply in developing countries such as the Philippines heavily relies on electricity generating companies which is a major industry that regulates electricity supply and its prices. Electricity is crucial in modern household and school operation, as it powers essential appliances

and instructional tools and devices that enhance the quality of living and assist the delivery of learning. These households and schools are connected on-grid which means that electricity supply for daily activities, from simple tasks like lighting a stove to illuminating the homes, streets and empowering teaching devices, are all dependent to electricity supplied by electric companies. However, research indicates that household energy consumption alone accounts for nearly one-third of global primary energy demand, thus, significantly impacting the environment (Bayudan & Dacuy, 2018; Han & Wei, 2021; Matsumoto, Mizobuchi, & Managi, 2021; Hanoum et al., 2024). It is crucial for communities to reduce household energy consumption to mitigate environmental impacts (Solà, de Ayala, Galarraga, et al., 2021; Muis et al., 2024; Zakiyah et al., 2024; Prajanti, Soesilowati, & Lestari 2025).

Since its discovery in 17<sup>th</sup> century, the use of electricity has progressed endlessly, becoming an indispensable commodity. While advancements in energy-efficient technologies and policies are within reach for domestic consumers, access comes at both economic and environment cost (Majeed, 2024). The detrimental impact of electricity production using fossil fuels, like coal, is evident (Wu & Shang, 2022; Lovering, Swain, Blomqvist, & Hernandez, 2022; Kosova, Hajrulla, & Kapciu, 2024; Halimah et al., 2024; Melinda et al., 2024) as these contribute to climate change and the frequent occurrence of natural disasters that destroys properties and sometimes cost lives especially in far flung areas. This heavy reliance on fossil fuels underscores the need for alternative energy solution, particularly in areas frequently affected by calamities, (Gamboa, 2022) which cut off electricity supply. Supply of electricity is indeed costly. A study of Uy (2016) comparing energy cost components among selected cities in Asia reveals that Manila, Philippines, has the third highest generation cost, highest grid cost and the third highest value added tax on energy. The high price of electricity can be attributed to various factors, including low generation capacity, governance failures, bureaucratic hurdles, and limited competition, (Ravago, 2023; Elpianora et al., 2024; Miharja et al., 2024; Wirnayanti et al., 2024). Considering that Manila is the economic capital of the country, the electricity supply is relatively steady which is the exact opposite in provinces and municipalities in the countryside such as in Sitio Cabog in Dingalan Aurora, where domestic and school consumers face costly and yet intermittent electricity services.

The Sitio Cabog in Dingalan Aurora is nestled in the rugged Sierra Madre mountains where the village faces persistent challenges due to its isolation and poor electricity supply. Frequent calamities, such as landslides and typhoons, exacerbate the community's struggles, leaving roads impassable, thus, cutting off access to essential services. The lack of reliable electricity hampers daily life. Students, in particular, bear the brunt of these hardships, as their education suffers from inadequate lighting and limited access to learning resources while teachers face significant obstacles in the delivery of effective instruction, as they lack access to teaching tools and resources that require electricity. The village's plight underscores the urgent need for infrastructure improvements and disaster preparedness to alleviate the impact of these challenges. However, such actions require huge budget allocation from the government not to mention the long bureaucratic and procedural processes which takes years to realize. Research studies provide valuable insights into the challenges faced by rural communities with poor electricity supply and their impact on education and daily life. The study of Francisco and Abrigo (2023) highlights how frequent electricity supply interruptions significantly affect local economies and limit the ability of local governments to provide essential services while Lozano and Taboada (2021) emphasized that limited electricity access hinders socioeconomic progress and educational opportunities. These findings underscore the urgent need for localized electricity supply sources to alleviate and improve the living conditions and educational outcomes in Sitio Cabog, Dingalan, Aurora.

Driven by the aforementioned condition and the urgent need to provide solution to address the frequent interruptions of electricity supply in the countryside where the university adopted school is located and as domestic and school consumers in the countryside often experience power outages which greatly affect the continuity of delivery of instruction, an immediate action in providing localized source arised. It is noteworthy to consider that there is actually a high demand for alternative electricity sources to power household and school devices at any available circumstances (Amador, 2017; Kamal, Mohammad, Ashaf, & Fernandez, 2022; Daco et al., 2024; Hasibuan et al., 2024). Various pathways for producing clean electricity, such as wind, solar, nuclear, and other renewable energy sources are gaining traction and each country is striving to provide sufficient energy for domestic consumers (Ritchie & Rosado, 2020; Holechek et al., 2022; Knez et al., 2022; Firmansyah et al., 2024; Laksono et al., 2024).

Regardless of source, researches indicate that electricity produced from renewable energy sources, is in the form of direct current (DC), (Alrikabi, 2014; Qiu et al., 2024; Castro, 2025) and is typically stored in batteries. Direct current flows in one direction whereas electricity provided by electrical grid operates on alternating (AC) and basic appliances and means of communication at home or at school require a 220Vac. Although this conflict has long been addressed through the conversion of some household appliances to be directly powered by 12V power supply or the use of inverters that converts DC to AC, and these solutions are readily available in the market, the problem lies in the complexity of connections needed to access such electricity source with ease and safety as the lack of understanding of users can result in significant financial losses if gadgets are damaged or destroyed due to improper use of the 12Vdc electricity supply.

This is where the device discussed in this paper comes in. An innovative AC-DC power supply versatile dual-mode distribution called ICPS-DMD device has been designed and developed to facilitate and control the use of electricity from a 12Vdc power supply (e.g. car batteries) for gadgets and devices which required 12Vdc or 220Vac current requirements that can be effectively utilized by users with ease and safety. Such device was registered to the Intellectual Property Office (IPOPhil) of the Philippines as an AC-DC Power Supply Distributor Box and under registration numbers 2-2017-000201, 2-2017-000202, 2-2017-000203, and 2-2017-000204 (IPOPhil e-gazette, 2018) with four sets of approved varying claims.

## RESEARCH METHOD

This study used developmental method of research. By undergoing product developmental process, the researcher had the opportunity to innovatively use locally available materials, make observations, perform accurate measurements, gather data, and tabulate and analyze information for the success of the research project (Kruachottikul et al., 2023; Cooper, R.G., 2029). The ICPS-DMD as a device was assessed as to its design, materials used, functionality, usability and safety. The development of the ICPS-DMD was conducted at the Industrial Electricity Shop (IES) of the Nueva Ecija University of Science and Technology (NEUST) in Cabanatuan City, Philippines.

The development of the ICPS-DMD device particularly addressed the needs of household users and classroom teachers who are residents of a far flung village in the mountainous town of Dingalan, Aurora named Sitio Cabog where the adopted school of NEUST is located - the Cabog Integrated School (CIS). Dingalan Aurora is frequently visited by typhoon resulting to often isolation of many villages, hence, electricity is frequently out of supply which hamper the delivery of learning and household operations. A total of ten (10) classroom teachers of CIS and ten (10) household parents of CIS pupils were purposively selected for the testing of the ICPS-DMD as to functionality, usability and safety. The design, materials used and safety of the device were assessed by five (5) licensed electrical engineers who are employed professors in the university.

The development of the Innovative AC-DC Power Supply Dual-Mode Distribution (ICPS-DMD) device started with the formulation of the product's circuit design. The circuit design guided the researcher in the proper connections of wires and parts towards a completed innovative product in response to the need of addressing the common problem of household users and classroom teachers on the alternative source of electricity especially during calamity period. The developed design likewise served as guide in the identification and collection of materials needed to construct the device. All materials needed were available in local electronics stores in Cabanatuan City where the University is located.

The construction of the ICPS-DMD was done by soldering, connecting and installing the various materials as identified. Once the construction is done, the device was subjected to assessment by licensed electrical engineers in the university to establish the status of the design, materials used and safety features. An instrument for this purpose was developed and validated. After minimum adjustments, the design of the device was submitted to the Intellectual Property Office of the Philippines to secure protection and established the novelty and authenticity of the developed device. After obtaining the patent recognition of the device, the ICPS-DMD was set for assessment in terms of functionality, usability and safety from the vantage of the target users who are teachers and parents of Cabog Integrated School. For this step, the second assessment instrument was developed and validated. Two assessment instruments for product development was designed by the researcher and made use of a 1-3 Likert Scale in assessing the design, materials used, functionality, safety, and usability of the device.

The research instrument underwent content, construct and face validations. As to content validity, the researcher solicited the expertise of the five (5) Industrial Electricity Shop teachers and another five (5) Electronics Shop teachers who decided on which aspects of the device needs assessment. The face and construct validity of the instrument was approved by the statistician and grammar experts. The reliability of the instrument was established using Cronbach’s alpha in SPSS v. 20 where reliability coefficient and internal consistency of test equivalent was computed equal to 0.94.

Before bringing the developed device to the target respondents for utilization and testing, the said device was submitted to the Intellectual Property Office of the Philippines (IPOPhil) as utility model for patent registration. After obtaining four patent certificates for four different claims the ICPS-DMD was ready and brought to the target Sitio Cabog and Cabog Integrated School in Dingalan, Aurora. After obtaining the necessary permits from local and school authorities, the ten (10) classroom teachers and ten (10) parents of students of Cabog Integrated School were purposively selected who utilized and assessed the functionality, usability and safety of the ICPS-DMD. The respondents were assisted by the researcher during the testing period.

Among the statistical tools used in analyzing the gathered data were weighed mean, one-tailed t-test for independent variables, One-way ANOVA and PostHoc Analysis for Multiple Comparison using SPSS v. 20. The gathered data were summarized using weighed mean. The computed weighted means were interpreted based on the following guide to verbal interpretation. 2.5-3.0 (Very Functional/ Very Safe/ Very Useful/ Very Good), 1.7-2.4 (Functional/ Safe/ Useful/ Good), 1.0-1.6 (Not Functional/ Not Safe/Not Useful/Poor). In comparing the assessments of the teachers and parents on functionality, usability and safety of the ICPS-DMD, one tailed t-test for independent variables was used. To compare the assessments made by five (5) licensed electrical engineers, One-Way Analysis of Variance and PostHoc Analysis for Multiple Comparison were used.

**RESULTS AND DISCUSSION**

**The Circuit Design**

The circuit diagram of the ICPS-DMD device which facilitates and controls the use of 12Vdc electricity supply for both 12Vdc and 220Vac powered household appliances and gadgets and instructional tools, is referred to as Figure 1.

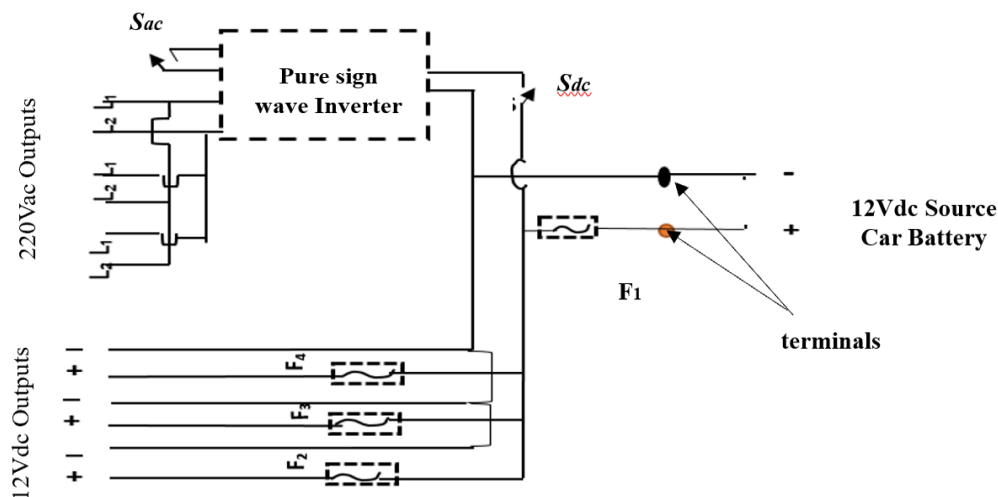

Figure 1. Circuit Diagram of the ICPS-DMD Device

The design of the ICPS-DMD device, along with all the material parts are indicated in the circuit diagram shown as Figure 1. Circuit diagram is a basic requirement when developing any electrically operated device as it serves as abstract representations of electrical circuits, allowing engineers and students to visualize and analyze the relationships between components such as fuse, switches, and power sources, (Zhang, 2020; Izadian, 2023; Tanti et al., 2025). In the presented circuit diagram, the entry of electricity from a 12Vdc power source which is typically a full charged car battery, is controlled by a 12Vdc control switch (*Sdc*) and a fuse (*F1*) for protection. Once the *Sdc* is closed, the electricity flows in two directions. Smith and Doe (2018) discussed how understanding

current direction aids in optimizing circuit design and improving energy efficiency. The circuit design of the ICPS-DMD provide two current directions for direct and alternating current.

In the first direction, the electricity flows to the part of the circuit and passes through a pure sign wave inverter connected in series with the source. The inverter converts the 12V direct current from the car battery to 220V alternating current as an output. Three parallel outlets for 220Vac outputs are connected in series with the inverter to provide 220V alternating current which are available to power 220Vac powered gadgets, appliances and instructional tools. The use of this 220Vac outlets is controlled by a 220Vac switch (*Sac*) which is connected in series with the inverter. Precautions must be observed when using this type of electricity, such as monitoring the time of use and power capacity of the 220Vac household gadgets, appliances and instructional tools. In the second direction, the electricity from the 12Vdc power source car battery, flows directly to a circuit connected in series with three parallel connected fuse boxes (F2, F3, and F4). These fuse boxes serve as protection while the 12Vdc electricity from the battery before it flows to three lighter jacks, which serve as 12Vdc outlets. These 12Vdc outlets are also connected in parallel to ensure equal amount of 12Vdc supply and can be used simultaneously. As a precaution, the 220Vac control switch (*Sac*) that controls the 220Vac circuit must be turned off (or opened) when 12Vdc electrical supply is intended to use. Several studies emphasize the critical importance of distinguishing between AC and DC directions in electrical systems. Zhang and Liu (2020) highlight how AC's bidirectional flow is essential for power transmission, while DC's unidirectional flow is ideal for stable and efficient operation in electronic devices. Brown and Green (2021) focus on the safety implications, noting that proper identification of current direction is crucial for preventing electrical hazards and ensuring system reliability.

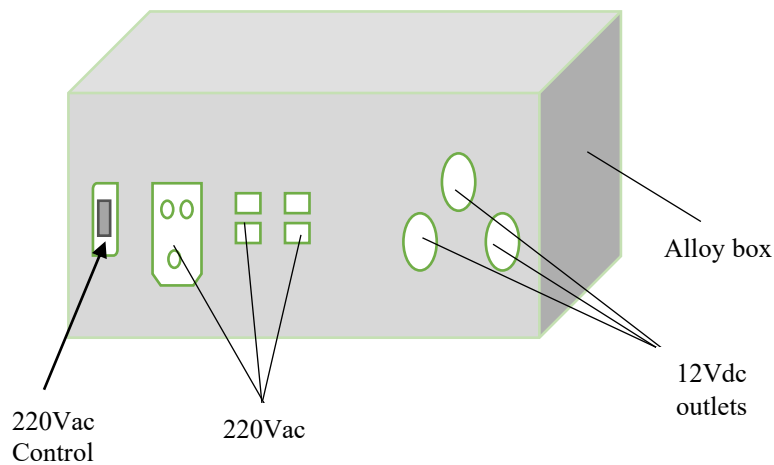

Figure 2. Front View of the ICPS-DMD device

As shown in Figure 2, there were 3 outlets for the 12Vdc powered gadgets in which equal amount of 12Vdc electricity supply is provided for gadgets and instructional tools. Another 3 outlets for 220Vac powered appliances and instructional tools are likewise available. A control switch (*Sac*) was provided to control the use of the 220Vac electricity supply.

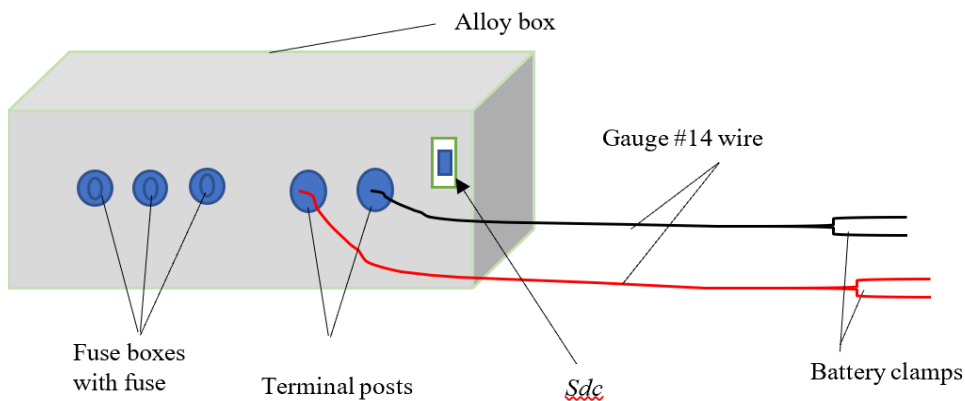

Figure 3. Rear View of the ICPS-DMD device

Figure 3 shows the rear view of the ICPS-DMD coll. The rear part of the device features three fuse boxes containing glass fuse tubes that provide protection in the circuit as these fuse tubes screen the current flowing in the 12Vdc circuit. Also shown in Figure 3 are the terminal posts to which the gauge #14 heavy-duty electrical wire is connected. Said electrical wire is color coded as black and red and at the ends are color coded battery clamps which are used to connect to the terminals of the 12Vdc-car battery. The entry of the 12Vdc electricity supply to the device is controlled by a *Sdc* switch. Simplicity and easy to follow electrical design of ICPS-DMD conformed with the stand of Pilz, F., Vajna, S., & Schabacker, M. (2020) and Eytam (2023) who’s studies showed that design elements influence perceived simplicity showing that structured layouts can make complex interfaces feel more user-friendly, and highlighting how users prefer deisgns that are visually and easy to understand.

Table 1 shows the quantities and descriptions of the materials used in constructing the ICPS-DMD device. The purpose of each material was likewise identified to guide future researchers and those who would like to develop their own ICPS-DMD device.

Table 1. Quantity, Description, and Uses of Materials in Constructing the ICPS-DMD Device

Materials	Quantity	Uses
Alloy Box	1 pc	A metal box serves as the housing of the circuit connections
Lighter jack	3 pcs	Outlets for 12V power supply
Fuse holder	3 pcs	Holder of fuse
Fuse	3 pcs	Provides protection for the electrical set-up in case of power failure or short circuit
See saw switch	2 pcs	Controls the 12V set-up and the inverter
Inverter	1 pc	Converts the 12V power supply to 220V power
AC open outlet	3 pcs	Outlets for 220V power supply
Binding post	2 pcs	Terminal posts for the wire
Auto wire	1 m	For the circuit connections inside the console box
Gauge #14 connecting wire	2m	Connects the battery clamps and the terminal posts
Battery clamp	2 pcs	Connects the wire and console box to the 12V power supply battery
Silver screws	10 pcs	To fix the positions of the inverter, lighter jacks, and outlets

Proper and careful selection of materials needed in the development of an electrically operated device is mandatory as these materials affects the performance, function, reliability, sustainability, and safety of the device, especiality of renewable energy devices (Gupta and Kandpal, 2020; Henriksson, 2021; Kumar & Singh, 2021; Curtis, 2023; Pjetri et al., 2024; Syahrul et al., 2025; Widiyanto et al., 2025), and weighing in the consequences of material selection in product development having great impact on innovation and sustainability.

**Construction of the AC-DC Power Supply Versatile Dual-Mode Distribution Device**

The construction of the ICPS-DMD device followed the circuit diagram shown in Figure 1 and used all the materials as listed in Table 1. By following the diagram in Figure 1, major parts of the device such as inverter, lighter jacks, switches, terminal posts, and outlets were secured inside an alloy box using silver screws. The fuse boxes, lighter jacks, switches, and terminal posts were respectively soldered in identified positions as described in the diagram. Precaution was observed regarding the directions of the current and colors of the wires used.

**Testing the Functionality, Usability and Safety of the ICPS-DMD device to Power the 220Vac and 12Vdc Powered Appliances, Gadgets and Instructional Tools**

Step 1. Connect the battery clamps to the positive (red terminal) and negative (black terminal) terminal poles of the 12Vdc battery. Switch on the control switch, *Sdc*, which controls the entry of electricity from the 12Vdc power source to the inverter.

Step 2. Connect a 220Vac electrically powered gadget to any of the three 220Vac marked outlets. Remember to switch on the control switch, *Sac*. This switch is connected to the inverter and is designed to control the use of the inverter.

Step 3. To use the 220Vac power supply, turn on the switches *Sdc* and *Sac* of the device and observe the functionality of the gadget.

Step 4. To stop the flow of the 220Vac current supply provided by the inverter, turn off the *Sac*. To stop the flow of 12Vdc electricity supply to the inverter, turn off the *Sdc*.

### Testing the Functionality, Usability & Safety of the ICPS-DMD device to Provide Multiple 12Vdc Outputs to Power 12Vdc Appliances, Gadgets and Instructional Tools

Step 5. Clamp the battery clamps to the positive (red terminal) and negative (black terminal) terminal poles of the 12V battery. The switch, *Sdc*, controls the entry of electricity from the 12Vdc power source.

Step 6. Make sure the *Sdc* is off to prevent the entry of the 12Vdc current supply to the inverter. Connect the lighter plug of 12Vdc gadget, appliances or instructional tools to any of the three available lighter jacks at the front portion of the device. Switch off the *Sdc* and observe the functionality of the gadgets powered by 12Vdc current supply.

Step 7. Label all the indicators, connections, and terminal posts on both the rear and front portions of the device for easy location, connections and over-all safety.

### Results of Assessments on the Design, Materials Used, Functionality, Usability and Safety of the ICPS-DMD Device

Table 2. F-test on Results of Assessment on Design, Materials Used and Safety of the ICPS-DMD

	Sum of Squares	Df	Mean Square	F	Sig.
Between Groups	.064	2	.032	2.233	.150
Within Groups	.172	12	.014		
Total	.236	14			

Table 2 shows the result of the ANOVA test for significant differences on the assessments of five licensed engineer experts who assessed the ICPS-DMD as a product. With a p-value of 0.150, the five experts' assessments showed no statistical variation. Thus, at 95% level of confidence, F-test value of 2.233 means that it is safe to claim that there is no significant difference in the assessments of the five engineers considering the design, materials used, and safety of the device as an alternative source of electricity supply in times when the Sitio Cabog is isolated due to calamities. Accordingly, the experts assessed that the circuit design followed the standard design where electricity may freely flow in two directions and in two forms such as direct current and alternating current. Such flow of electricity can also be controlled as shown in the design ensuring safety. The materials for the construction of the device can easily be found in local electronics store hence reproduction of the device is possible. The studies of Liberman-Pincu and Biotan (2021) and Kwahk (2000) accentuated the critical role of experts' assessments in ensuring the effectiveness, safety, and usability of electrical devices. Such assessment be made systematic adopting models in product development, focusing on user-centered approaches to enhance usability and safety (Vrusho, et al., 2025) as done in the development and assessment of ICPS-DMD.

Table 3. PostHoc Analysis for Multiple Comparison

			Mean Difference (I-J)	Std. Error	Sig.	95% Confidence Interval	
						Lower Bound	Upper Bound
Scheffe	1.00	2.00	-.08000	.07572	.586	-.2911	.1311
		3.00	-.16000	.07572	.150	-.3711	.0511
	2.00	1.00	.08000	.07572	.586	-.1311	.2911
		3.00	-.08000	.07572	.586	-.2911	.1311
	3.00	1.00	.16000	.07572	.150	-.0511	.3711
		2.00	.08000	.07572	.586	-.1311	.2911
Bonferroni	1.00	2.00	-.08000	.07572	.935	-.2905	.1305
		3.00	-.16000	.07572	.169	-.3705	.0505
	2.00	1.00	.08000	.07572	.935	-.1305	.2905
		3.00	-.08000	.07572	.935	-.2905	.1305
	3.00	1.00	.16000	.07572	.169	-.0505	.3705
		2.00	.08000	.07572	.935	-.1305	.2905

\*Dependent b=Variable: Assessment of Engineer Experts 1\* = Design, 2\* = Functionality, 3\* = Safety

Moreover, analysis shown on Table 3 and after conducting multiple comparison through Post Hoc Analysis, individually, it was revealed that there is no significant differences in the assessment on the design, materials used, and safety since all p values across each variable is less than the p critical value of 0.05. Hence, it is claimed that the assessments of the experts are comparable considering the design, materials used and safety of the product as an alternative and sustainable localized source of electricity for household and classroom use. Studies conducted by Kumar and Singh (2021), Chen and Zhao (2020) and Tanaka and Suzuki (2019) emphasized the critical role of comprehensive assessments by experts in ensuring the effectiveness and safety of electrical devices to ensure the reliability and sustainability of electrical systems, the importance of selecting appropriate materials to enhance device durability and safety and highlighted the need for usability and functionality evaluations to optimize energy efficiency and user satisfaction, as done to establish a credible output such as the ICPS-DMD.

Table 4. t-test Analysis on the Assessment of Teachers and Parents

		Levene's Test for Equality of Variances		t-test for Equality of Means						
		F	Sig.	T	df	Sig. (2- tailed)	Mean Difference	Std. Error Difference	95% Confidence Interval of the Difference	
								Lower	Upper	
Assessment of Teachers and Parents	Equal variances assumed	.203	.676	-.180	4	.866	-.03333	.18559	-.54862	.48195
	Equal variances not assumed			-.180	3.806	.867	-.03333	.18559	-.55915	.49248

\*Independent Sample Test

Table 4 shows the result of independent sample t test conducted to determine if there is significant difference between the assessments of parents and teachers on the device considering its functionality, usability, and safety. As revealed in the table, the p value of 0.676 is greater than the p critical value of 0.05, hence it is claimed that at 95% level of confidence there is no significant difference between the assessments of teachers and parents considering the functionality, usability and safety of the device in providing alternative and sustainable source of electricity supply. Accordingly, the teachers and parents who were users of the device found that the device effectively functions as it can provide steady supply of electricity specially during calamity seasons when on-grid supply of electricity is cut. Such technology-based user-centered assessments improve improve precision and engagement, facilitating smoother communication with parent-users (Chen, 2023; Schoenardie, 2022).

Since all connections are color coded, the colors black and red serves as guide in the connection and so they themselves can operate and use the device safely even without assistance describing its very usable and safe status as source of localized electricity for household and instructional purposes. Such use of color coding in wires and connectors ensure safety, usability and compliance in electrical standard code highlighting the importance in preventing electrical accident (Jaaffar et al., 2020).

## CONCLUSION

Generally, the developed ICPS-DMD is therefore an alternative and safe source of electricity for community and school use in times of calamity and isolation, it is a localized sustainable energy solution addressing Sustainable Development Goal number 7 on affordable and clean energy. On the device, the developed Innovative AC-DC Power Supply Dual-Mode Distribution (ICPS DMD) device passed the assessment of licensed electrical engineers with no significant differences in the assessed design, materials used and safety with F= test value equal to 2.233. PostHoc Multiple comparison revealed similar findings. Accordingly, the design and materials used were very good and the circuit design provides safety features for the safety of the users. The device was likewise assessed and found very functional, very safe and very usable by the parents and teachers and statistically found no significant differences in the assessment with t-test value of 1.8. The results showed that the device can functionally and safely provide electricity supply to power both 12Vdc and 220Vac powered household gadgets and instructional devices. On novelty and originality, the innovative product was registered to the Intellectual Property Office of the Philippines as an AC-DC Power Supply Distributor Box under four registration numbers 2-2017-000201, 2-2017-000202, 2-2017-000203, and 2-2017-000204.

## ACKNOWLEDGMENTS

I would like to thank the Nueva Ecija University of Science and Technology for the funding of this research. This work was supported by the Research Services Department (RSD) of the University. Due acknowledgement is likewise given to the parents and teachers of the adopted Cabog Integrated School who served as the beneficiary who utilized the device as part of the technology transfer program of the University.

## AUTHOR CONTRIBUTIONS

Author creates articles and Analyzes research data and is responsible for research.

## CONFLICTS OF INTEREST

The author(s) declare no conflict of interest.

## REFERENCES

- Alrikabi, N.K.M.A. (2014). Renewable Energy Types. *Journal of Clean Energy Technologies*. <https://doi.org/10.7763/JOCET.2014.V2.92>.
- Amador, R. (2017). Rural renewable energy-based infrastructure of the Philippines. *Georgetown University Thesis*. [URP-CAPSTONE-Amador-Ryan-Paper.pdf](https://doi.org/10.7763/JOCET.2014.V2.92)
- Bayudan-Dacuycuy, C., & Dacuycuy, L. B. (2018). Urban and rural households' energy use: Sets, shocks, and strategies in the Philippines. *Philippine Institute for Development Studies Discussion Paper Series*, 2018-01. <https://pidswebs.pids.gov.ph/CDN/PUBLICATIONS/pidsdps1801.pdf>
- Brown, T., & Green, P. (2021). Understanding current flow: Implications for electrical design and safety. *IEEE Transactions on Power Systems*, 36(4), 789-798. <https://doi.org/10.1109/TPWRS.2021.3051111>
- Castro, R. (2025). The effects of chemistry virtual laboratories in academic achievement of secondary level learners: A meta-analysis. *Integrated Science Education Journal*, 6(1), 24-37. <https://doi.org/10.37251/isej.v6i1.1379>
- Chen, Y., & Zhao, L. (2020). Usability and functionality assessments in the development of energy-efficient electrical devices. *Energy and Environment Research*, 12(4), 67-80. <https://doi.org/10.1080/17513758.2020.1811111>
- Chen, D. (2023). Use of technology-based assessments: A systematic review. *Global Education Monitoring Report*. <https://doi.org/10.54676/QGYW3130>
- Curtis, H. (2023). Electrical engineering circuit design: Principles and best practices. *IEEE Transactions on Engineering Design*, 36(4), 789-798. <https://doi.org/10.1109/TEDES.2023.3241111>

- Daco, M. A. D., Dacilo, L. C., Distor, K. S. A., Gabane, J. M., & Mendoza, G. M. (2024). A proposed project of hydroelectric generator as an alternative source of electricity: Vol. 3, No ID. *Ascendens Asia Singapore – Bestlink College of the Philippines Journal of Multidisciplinary Research*, 3(1D)
- Elpianora, E., Berou, M., Kong, X., Hun, K., & Azadegan, E. (2024). Fourth order runge-kutta and gill methods in numerical analysis of predator-prey models. *Interval: Indonesian Journal of Mathematical Education*, 2(2), 164-177. <https://doi.org/10.37251/ijome.v2i2.1366>
- Eytam, E. (2023). Effect of design elements on simplicity, usability, and product preference: A video conference application case study. *Interacting with Computers*, 35(3), 461-480. <https://doi.org/10.1093/iwc/iwad030>
- Firmansyah, E., Baluta, I. B., & Elfaituri, K. (2024). The correlation between students' problem-solving abilities and their mathematical thinking in high school mathematics education. *Interval: Indonesian Journal of Mathematical Education*, 2(2), 132-140. <https://doi.org/10.37251/ijome.v2i2.1343>
- Francisco, A. K. & Abrigo, M.R.M. (2023). Electricity supply interruptions and its impact on local economies. *Philippine Institute for Development Studies*. Discussion paper series #2023-49. <https://pidswebs.pids.gov.ph/CDN/document/pidsdps2349.pdf>
- Gamboa, R. (2022). Power rates: up, up, and away. *The Philippine Star*. Business Section, September 27, 2022. <https://www.philstar.com/business/2022/09/27/2212430/power-rates-up-up-and-away>.
- Gupta, N., & Kandpal, K. (2020). Material selection techniques in materials for electronics. *Multiscale Modelling of Advanced Materials*, 1–15. [https://doi.org/10.1007/978-981-15-2267-3\\_1](https://doi.org/10.1007/978-981-15-2267-3_1)
- Han, X., Wei, C. (2021). Household energy consumption: state of the art, research gaps, and future prospects. *Environ Dev Sustain*, 23, 12479–12504. <https://doi.org/10.1007/s10668-020-01179-x>.
- Hanoum, N. A., Villaverde, K., Saputra, Y., Nuhuyeva, Åöhla, & Ye, T. (2024). Design and development of tempe fermentation tool based on fuzzy method to determine tempe maturity level. *Journal of Educational Technology and Learning Creativity*, 2(2), 235-255. <https://doi.org/10.37251/jetlc.v2i2.1418>
- Hasibuan, S., Chu, C. T., & Godh, W. A. (2024). Enhancing creative thinking in circle topics through the realistic mathematics learning approach. *Interval: Indonesian Journal of Mathematical Education*, 2(2), 106-114. <https://doi.org/10.37251/ijome.v2i2.1148>
- Halimah, H., Putri, D. E., Wulandari, W., Adewumi, S. E., & Arce-Calderón, X. (2024). Contextual pop up book as an innovative learning media in social science subjects in elementary schools. *Journal of Educational Technology and Learning Creativity*, 2(2), 209-216. <https://doi.org/10.37251/jetlc.v2i2.1121>
- Henriksson, F. (2021). On material selection and its consequences in product development. *Linköping Studies in Science and Technology*, Dissertation No. 2161. <https://www.researchgate.net/publication/354928692>
- Holechek, J.L.; Geli, H.M.E.; Sawalhah, M.N.; Valdez, R. (2022). A global assessment: Can renewable energy replace fossil fuels by 2050? *Sustainability*, 14, 4792. <https://doi.org/10.3390/su14084792>.
- Intellectual Property Office of the Philippines (2018). 12V/500 power supply AC-DC distributor box. e-gazette 21 (120), page 1-2. <https://www.ipophil.gov.ph>
- Izadian, A. (2023). Fundamentals of modern electric circuit analysis and filter synthesis. *Introduction to Electric Circuits* (pp. 1–9). Springer. [https://doi.org/10.1007/978-3-031-21908-5\\_1](https://doi.org/10.1007/978-3-031-21908-5_1)
- Jaaffar, A.H., Selamat, M. N., & Ismail, M. N. (2020). Barriers to standardization of new cable color code for electrical installation. *European Proceedings of Social and Behavioural Sciences*, 99, 123-135. <https://doi.org/10.15405/epsbs.2020.12.05.99>
- Kamal, M. M., Mohammad, A., Ashraf, I., & Fernandez, E. (2022). Rural electrification using renewable energy resources and its environmental impact assessment. *Environmental Science and Pollution Research*, 29, 86562–86579. <https://doi.org/10.1007/s11356-022-22001-3>
- Kosova, R., Hajrulla, S., Xhafaj, E., & Kapçiu, R. (2024). Urban flood resilience: A multi-criteria evaluation using AHP and TOPSIS. *Jurnal Ilmiah Ilmu Terapan Universitas Jambi*, 8(2), 828–841. <https://doi.org/10.22437/jiituj.v8i2.35387>
- Knez, S., Šimić, G., Milovanović, A. et al. (2022). Prices of conventional and renewable energy as determinants of sustainable and secure energy development: regression model analysis. *Energy*

- Sustain Soc*, 12, 6. <https://doi.org/10.1186/s13705-022-00333-9>
- Kruachottikul, P., Dumrongvute, P., Tea-makorn, P., Kittikowit, S., & Amrapala, A. (2023). New product development process and case studies for deep-tech academic research to commercialization. *Journal of Innovation and Entrepreneurship*, 12, Article 48. <https://doi.org/10.xxxx/abcd1234>
- Kumar, R., & Singh, A. (2021). Material selection and safety considerations in the design of renewable energy devices. *Renewable Energy Journal*, 45(2), 123-135. <https://doi.org/10.xxxx/abcd1234>
- Kwahk, J. (2000). Evaluation of product usability: Development and validation of usability dimensions and design elements based on empirical models. *International Journal of Industrial Ergonomics*, 25(3), 231-243. <https://doi.org/10.xxxx/ijk19101>
- Laksono, P. J., Suhadi, S., & Efriani, A. (2025). Unveiling STEM education conceptions: insights from pre-service mathematics and science teachers. *Integrated Science Education Journal*, 6(1), 54-61. <https://doi.org/10.37251/isej.v6i1.1387>
- Liberman-Pincu, E., & Bitan, Y. (2021). Functionality, usability, look-and-feel, and evaluation: A novel user-centered product design methodology. *Applied Sciences*, 11(3), 985. <https://doi.org/10.3390/app11030985>
- Lovering J, Swain M, Blomqvist L, Hernandez RR (2022). Land-use intensity of electricity production and tomorrow's energy landscape. *PLoS ONE* 17(7): e0270155. <https://doi.org/10.1371/journal.pone.0270155>
- Lozano, L. & Taboada, E. B., (2021). The poor of electricity; How effective it is in promoting sustainable development in rural off-grid islands in the Philippines? *MDPI Journal*, 14(9), 2705, <https://doi.org/10.3390/en14092705>
- Majeed, D. A., et al. (2024). Data analysis and machine learning applications in environmental management. *Jurnal Ilmiah Ilmu Terapan Universitas Jambi*, 8(2), 398–408. <https://doi.org/10.22437/jiituj.v8i2.32769>
- Matsumoto, S., Mizobuchi, K., & Managi, S. (2021). Household energy consumption. *Environmental Economics and Policy Studies*, 24, 1–5. <https://doi.org/10.1007/s10018-021-00331-9>
- Melinda, S., Feizi, F., & Monfared, P. N. (2024). Transforming religious learning with macromedia flash 8: Improving students' understanding of the material on faith in the apostles. *Journal of Educational Technology and Learning Creativity*, 2(2), 201-208. <https://doi.org/10.37251/jetlc.v2i2.1100>
- Miharja, M. A., Bulayi, M., & Triet, L. V. M. (2024). Realistic mathematics education: Unlocking problem-solving potential in students. *Interval: Indonesian Journal of Mathematical Education*, 2(1), 50-59. <https://doi.org/10.37251/ijome.v2i1.1344>
- Muis, A., Pholboon, M., & Kamali, A. N. (2024). Geomics as interactive geography learning media: a development study on environmental material in high schools. *Journal of Educational Technology and Learning Creativity*, 2(2), 192-200. <https://doi.org/10.37251/jetlc.v2i2.1089>
- Pilz, F., Vajna, S., & Schabacker, M. (2020). Achieving simplicity: A consideration of a systematic approach. *Proceedings of the Design Society: DESIGN Conference*, 1, 2345-2354. <https://doi.org/10.1017/dsd.2020.291>
- Pjetri, A., Bardhi, A., & Dume, G. (2024). Sensorless speed estimation of three phase induction motors based on dynamic model. *Jurnal Ilmiah Ilmu Terapan Universitas Jambi*, 8(2), 610–621. <https://doi.org/10.22437/jiituj.v8i2.32862>
- Prajanti, S. D. W., Soesilowati, E., & Lestari, E. P. (2025). Sustainability strategy of integrated organic farming based on circular economy in realizing sustainable agriculture and food system. *Jurnal Ilmiah Ilmu Terapan Universitas Jambi*, 9(2), 527–545. <https://doi.org/10.22437/jiituj.v9i2.39889>
- Qiu, L., Ikeda, F., & Yamashita, N. (2025). Development and validation of a taxonomy for specific questions based on deficiencies in logical reasoning. *Integrated Science Education Journal*, 6(1), 6-14. <https://doi.org/10.37251/isej.v6i1.1102>
- Ravago, Majah-Leah V., (2023). The nature and causes of high Philippines electricity price and potential remedies. *Ateneo Center for Economic Research and Development*. Working Paper No.2023-01. [https://www.ateneo.edu/sites/default/files/2023-01/AdMU%20WP%202023-01\\_0.pdf](https://www.ateneo.edu/sites/default/files/2023-01/AdMU%20WP%202023-01_0.pdf)
- Ritchie, H. & Rosado, P. (2020). “Electricity Mix” Published online at OurWorldinData.org. Retrieved from <https://ourworldindata.org/electricity-mix>
-

- Schoenardie, R. P. (2022). Usability in product design: The importance and need for systematic assessment models in product development. *Work (Reading, Mass.)*, 41(1), 123-135. <https://files.eric.ed.gov/fulltext/ED588476.pdf>
- Smith, J., & Doe, A. (2018). The role of current direction in optimizing electrical circuit performance. *International Journal of Power Electronics and Drive Systems*, 10(2), 123-1. <https://doi.org/10.xxxx/efgh5678>
- Solà, M.d.M., de Ayala, A., Galarraga, I. *et al.* (2021). Promoting energy efficiency at household level: A literature review. *Energy Efficiency* 14, 6. <https://doi.org/10.1007/s12053-020-09918-9>
- Syahrul, A. R., Suryana, S., Hendrayati, H., & Furqon, C. (2025). The dynamics of entrepreneurship education in higher education: The role of family background and environment in developing entrepreneurial skills. *Journal Evaluation in Education (JEE)*, 6(2), 590-600. <https://doi.org/10.37251/jee.v6i2.1540>
- Tanaka, H., & Suzuki, K. (2019). Evaluating safety and performance in the design of electrical energy systems. *Journal of Electrical Engineering and Technology*, 14(3), 45-60. <https://doi.org/10.xxxx/ijk19101>
- Tanti, T., Utami, W., Deliza, D., & Jahanifar, M. (2025). Investigation in vocation high school for attitude and motivation students in learning physics subject. *Journal Evaluation in Education (JEE)*, 6(2), 479-490. <https://doi.org/10.37251/jee.v6i2.1452>
- Uy, F. I. (2016). Energy pricing in the Philippines and its effect on economic growth. *Columbia University Libraries*. <https://doi.org/10.7916/D8Z31ZRK>
- Vrusho, B. *et al.* (2025). Improving energy efficiency strategy in residential building. *Jurnal Ilmiah Ilmu Terapan Universitas Jambi*, 9(1), 380–392. <https://doi.org/10.22437/jiituj.v9i1.37924>
- Widiyanto, D., Novitasari, N., Syahroni, M., Prananda, A. R., Mujtahidah, T., & Istiqomah, A. (2025). Development and validation of the vark instrument in citizenship education learning: A structural equation modeling approach for more accurate learning style measurement. *Journal Evaluation in Education (JEE)*, 6(2), 556-564. <https://doi.org/10.37251/jee.v6i2.1561>
- Wirnayanti, W., Craig, J., & Malatjie, J. F. (2024). Comparing the impact of problem solving vs. problem posing approaches on mathematics achievement in junior high school. *Interval: Indonesian Journal of Mathematical Education*, 2(2), 90-98. <https://doi.org/10.37251/ijome.v2i2.1094>
- Wu, J., Shang, J. (2022). Environmental and energy implications of coal-based alternative vehicle fuel pathway from the life cycle perspective. *Environ Sci Pollut Res* 29, 56727–56738. <https://doi.org/10.1007/s11356-022-19424-3>
- Zakiyah, Z., Boonma, K., & Collado, R. (2024). Physics learning innovation: song and animation-based media as a learning solution for mirrors and lenses for junior high school students. *Journal of Educational Technology and Learning Creativity*, 2(2), 183-191. <https://doi.org/10.37251/jetlc.v2i2.1062>
- Zhang, H. (2020). Applications research of electrical control circuit design. *Journal of Physics: Conference Series*, 1449(1), 012110. <https://doi.org/10.1088/1742-6596/1449/1/012110>
- Zhang, H., & Liu, Y. (2020). Comparative analysis of AC and DC systems in modern electrical engineering. *Journal of Electrical Engineering and Technology*, 15(3), 45-60. <https://doi.org/10.xxxx/abcd1234>